



# D-LOCK PROTILT™ HYDRAULIC COUPLER

TILT THE WORLD YOUR WAY –  
WORLD CLASS UPFRONT





# D PROTILT™ COUPLER



**3 YEAR  
WARRANTY**  
OR 3000 HOURS  
\*WHICHEVER OCCURS  
FIRST

UP TO  
180° OF TILT

**THE D-LOCK PROTILT™  
IS OUR MOST ADVANCED  
TILTING QUICK COUPLER  
TO DATE.**

## ALL-ANGLE PERFORMANCE

### TILT RANGE:

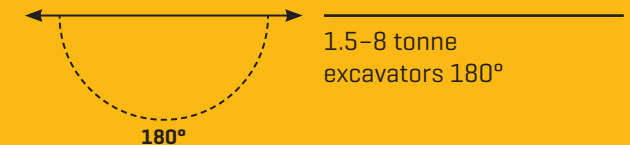

- Compliant with ISO13031, AS13031-2023 and all major Contractor policies, the D-Lock Protilt™ Coupler heralds a new era in fully automatic quick couplers.
- The D-Lock Protilt™ delivers durability and versatility in even the toughest environments.

# LIGHTEST, LOWEST AND STRONGEST

## D PROTILT™ COUPLER

3.5-15 TONNE EXCAVATORS



16-65 TONNE EXCAVATORS



## 3.5 - 15 TONNE MACHINES

- Side bolt mounting, reinforced with key and dowel to guarantee the highest degree of safety and stability.
- No welding = no seal damage internally and no distortion to the barrel.



SCAN TO VIEW 3D MODEL

## 16 - 65 TONNE MACHINE

- The top mount uses an oversized plate that is machined to remove dead weight.
- This design minimises welding, and the bolt-through ear design ensures a narrow coupler with maximum strength.
- It guarantees the highest degree of safety and stability.
- No welding = no internal seal damage and no barrel distortion.



SCAN TO VIEW 3D MODEL

# KEY FEATURES OF THE D-LOCK PROTILT™ COUPLER

**COMPACT DESIGN:**

Improves machine performance and provides better visibility.

**UP TO 180 DEGREES OF TILT:**

Allows operators to tilt attachments rather than moving the entire machine, enhancing productivity and versatility.

**SIMPLIFIED CONNECTIONS AND CONTROLS:**

Easy to operate with streamlined hydraulic connections.

**ACTUATOR WITH TWO MOVING PARTS:**

Precision-built actuator ensures trouble-free operation and is triple sealed for durability.

**ONLY FOUR HYDRAULIC LINES REQUIRED:**

Two for the tilt and two for the hydraulic coupler.

**FULLY GUARDED HOSES:**

Protects hoses from damage during operation.

**NO UNWANTED MOVEMENT:**

Ensures stable and controlled operation.

**NO PINS OR BUSHES TO WEAR OUT:**

Maintenance-free design for long-term reliability.

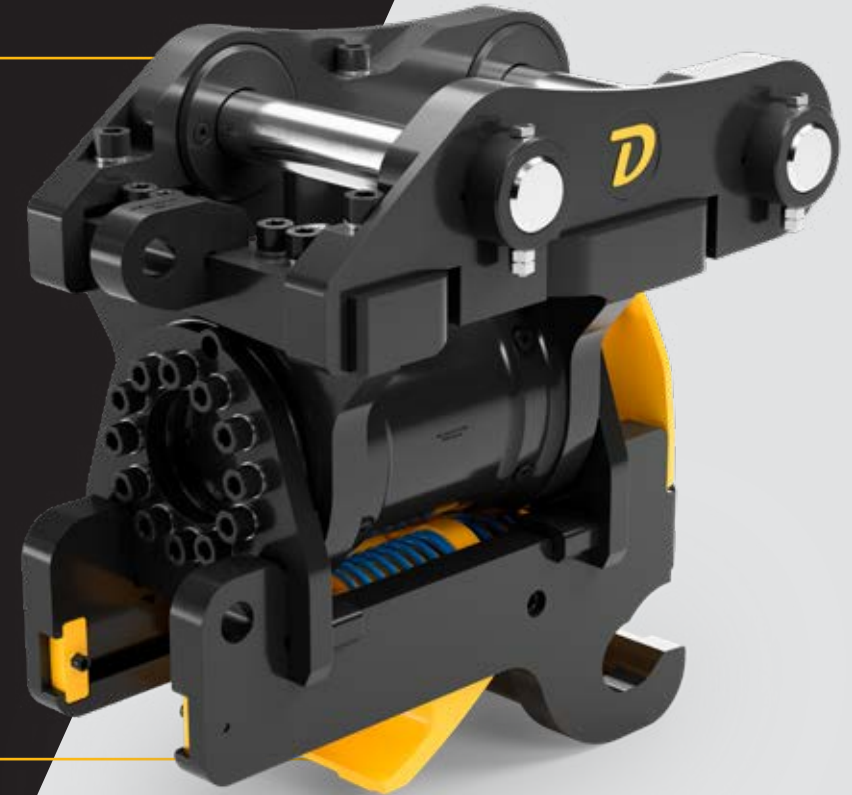

THESE FEATURES MAKE THE D-LOCK TILT COUPLER  
POWERFUL, VIRTUALLY MAINTENANCE-FREE, AND IDEAL  
FOR IMPROVING MACHINE PRODUCTIVITY AND VERSATILITY.

1.5-8 TONNE  
EXCAVATORS 180°

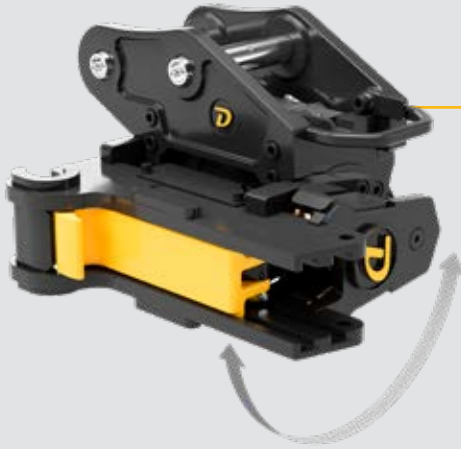

12-15 TONNE  
EXCAVATORS 140°



16-29 TONNE  
EXCAVATORS 140°  
32-65 TONNE  
EXCAVATORS 100°

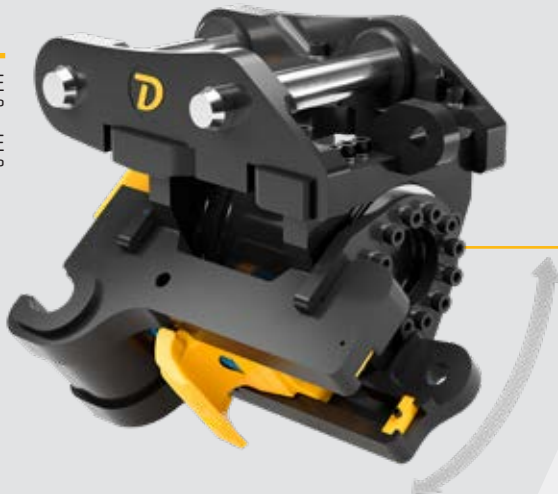

## **D** PROTILT™ COUPLER

### **DUAL PIN LOCKING SYSTEM (DPL+):**

Locks both front and rear pins independently of the primary lock, ensuring attachments remain securely engaged even in the event of loss of engagement force.

### **AUTOMATIC FRONT LOCK:**

Locks the front pin automatically if the rear pin is not secured, preventing accidental detachment.

### **MULTI PIN CAPABILITY:**

Picks up all attachments in the same weight class, with multi-pin diameter capability from O80 class and above.

### **HIGHLY VISIBLE FRONT LOCK INDICATOR:**

Provides clear visibility to confirm the front lock is engaged.

### **SAFETY SYSTEM INDEPENDENT OF GRAVITY:**

Does not rely on gravity for locking, ensuring secure operation in all conditions.

### **COMPACT DESIGN:**

Improves machine performance with minimal moving parts and only two hydraulic lines.

### **SIMPLE UNLOCK PROCEDURE:**

Designed to release attachments only when the operator intends to do so, eliminating accidental releases.

### **NO GREASING OR LUBRICATION REQUIRED:**

Maintenance-free design for ease of use.



WARRANTY: INDUSTRY LEADING 3 YEAR OR 3000 HOUR [WHICHEVER OCCURS FIRST] WARRANTY.

# KEY FEATURES OF THE D-LOCK PROTILT™ COUPLER

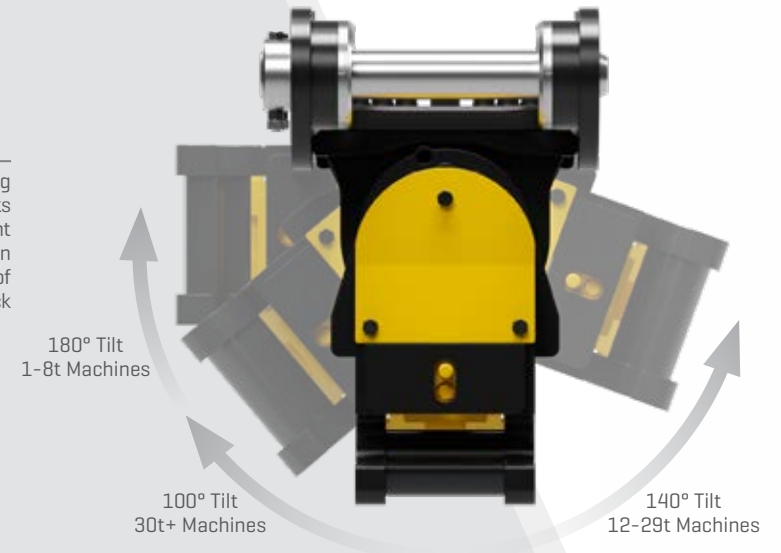
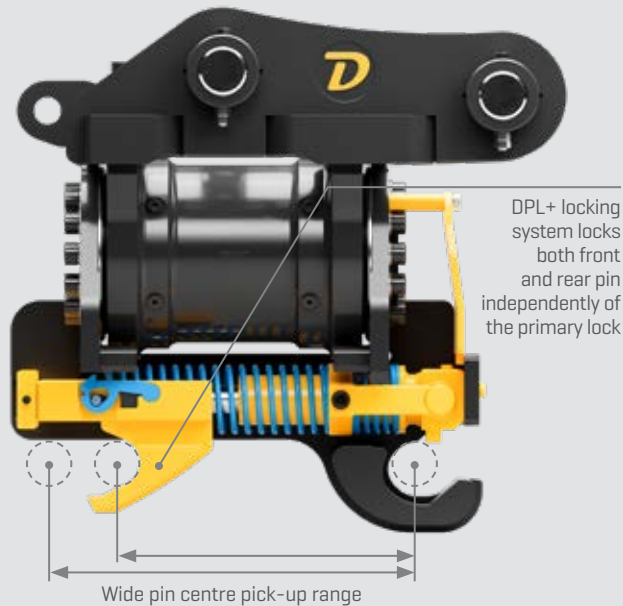
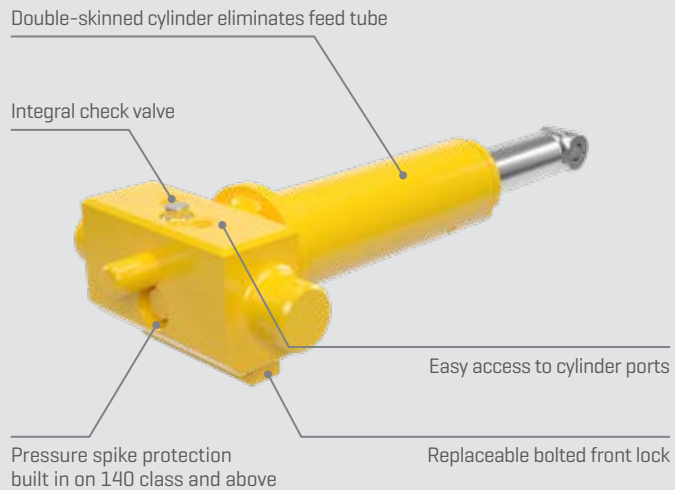

## **PRESSURE SPIKE PROTECTION:**

Built-in protection for 140 class and above to handle pressure spikes.

## **REPLACEABLE BOLTED FRONT LOCK:**

Allows for easy replacement and maintenance.

## **INTEGRAL CHECK VALVE:**

Ensures safety by preventing unintended movement of the cylinder.

## **WIDE PIN CENTRE PICK-UP RANGE:**

Accommodates a variety of pin sizes and configurations.

Double-skinned cylinder eliminates feed tube.

Easy access to cylinder ports.

The D-Lock Coupler comes with an industry-leading warranty of 3 years or 3000 hours, whichever occurs first.

## **MORE PRECISE OPERATION:**

High-holding torques and precise manufacture ensure the exact maintenance of the selected position.

The advanced helical gear technology enables a tilt angle of up to 180 degrees to the left and right, surpassing the capabilities of cylinder-type tilt couplers. This design delivers maximum efficiency and versatility across a broader range of work environments.

## SPECIFICALLY DESIGNED FOR EXCAVATOR ATTACHMENTS

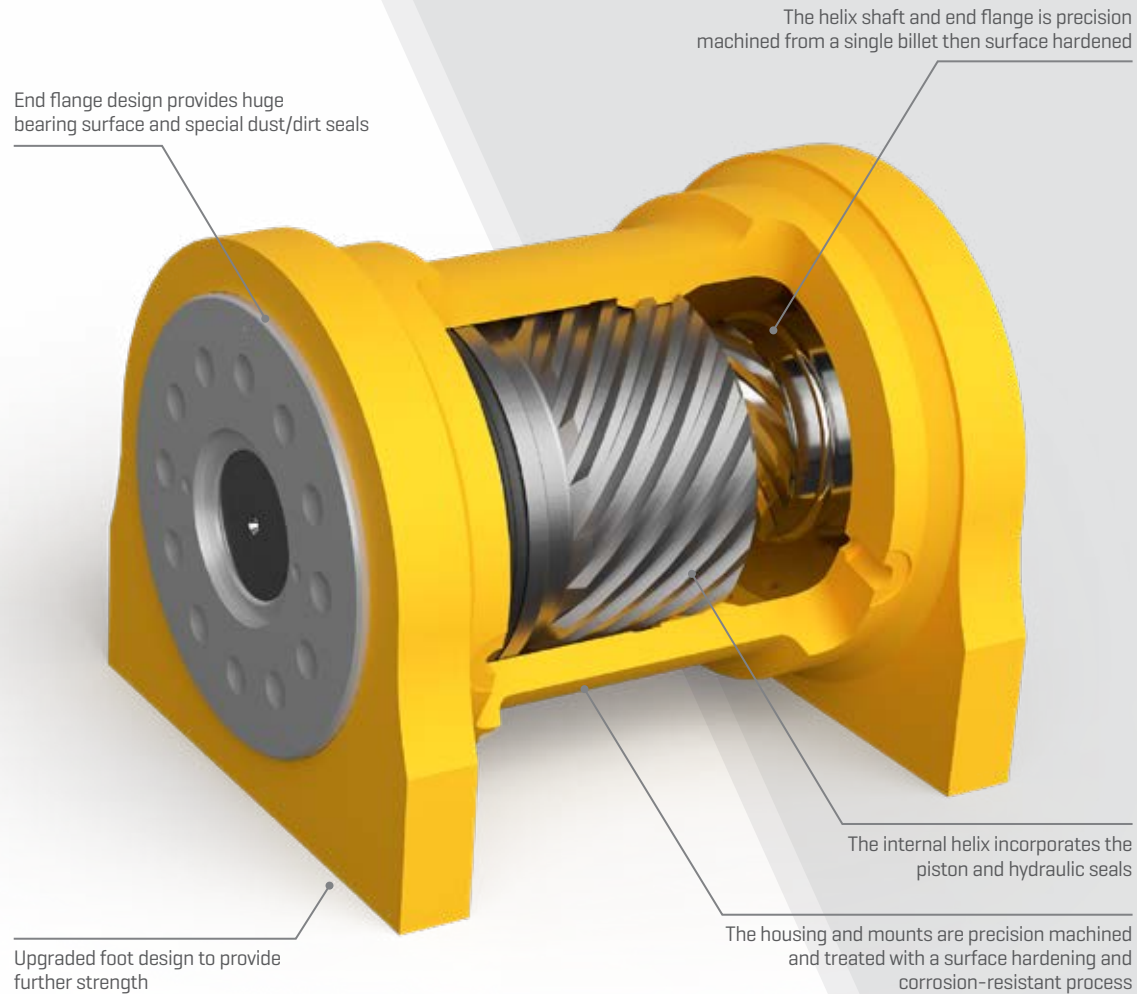

## THE INTERNALS: DOHERTY POWER ACTUATOR AT A GLANCE

- Operating pressure up to 250 BAR
- Slim structure
- Maintenance-free
- Multiple connection ports
- Triple-sealed
- Simple assembly
- Only two moving parts
- Integral relief valve 055 >
- Wide tilting range, up to 180 degree tilt range

The helix shaft and end flange is precision machined from a single billet then surface hardened.

End flange design provides huge bearing surface and special dust/dirt seals.

The internal helix incorporates the piston and hydraulic seals.

The housing and mounts are precision machined and treated with a surface hardening and corrosion resistant process.

## AN ENTIRELY NEW DEVELOPMENT - THE SERIES 2.0 ACTUATORS

3.5 – 15 Tonne class series 2 actuators lower weight, and provide greater torque due to shaft improvements. The enclosed wiper seal is now mounted inside instead of externally as before. This provides the same functionality, but it is now protected from the effects of external forces such as UV radiation and high pressure cleaners.

### DETAILS

- Lower weight, greater torque
- Enclosed wiper
- 3.5-15 Tonne class excavators
- Operating pressure increased to 250 BAR
- Maintenance-free
- Manufactured in Germany

The compact four-part construction made from high-quality materials and its high-precision manufacturing, make the Doherty Actuator the most robust rotary actuator in its class.

THE RIGHT CHOICE  
FOR HARSH EVERYDAY CONDITIONS

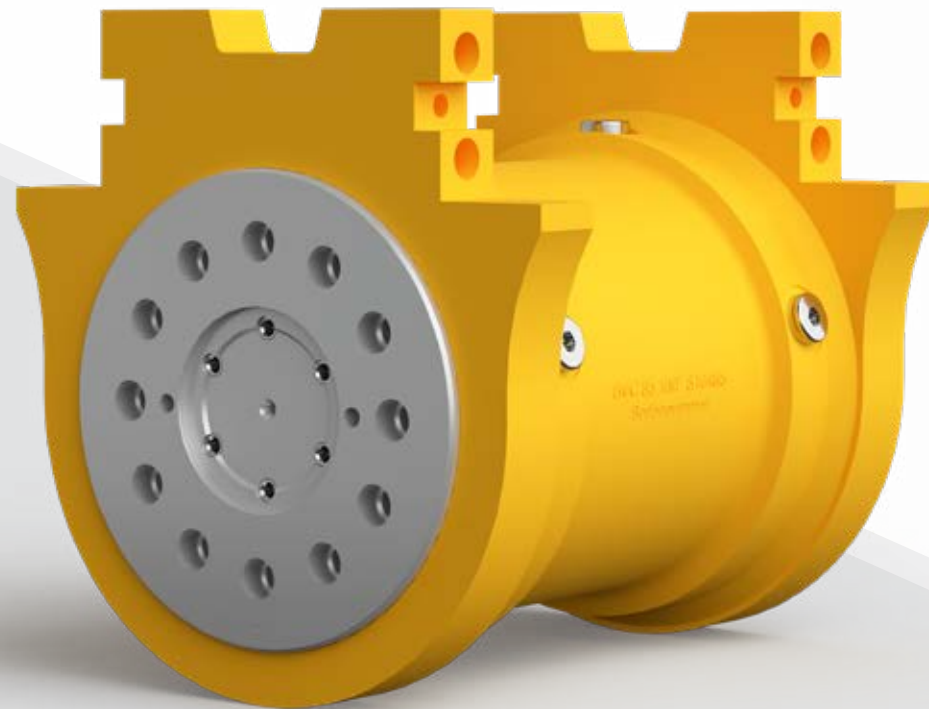

BOLTING, NOT WELDING, ENSURES  
NO DISTORTION TO THE ACTUATOR

# THE PROTILT™ ACTUATOR

**DURABILITY:** Protection against wear, tear and rust thanks to special manufacturing, annealing and hardening processes.

**CONSTANT TORQUE/HOLDING TORQUE:** Regardless of the operating angle.

**SIMPLICITY:** Only 4 main components making it simple and easy to service.

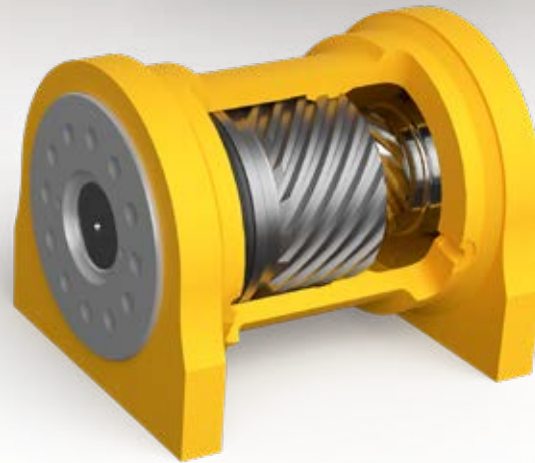
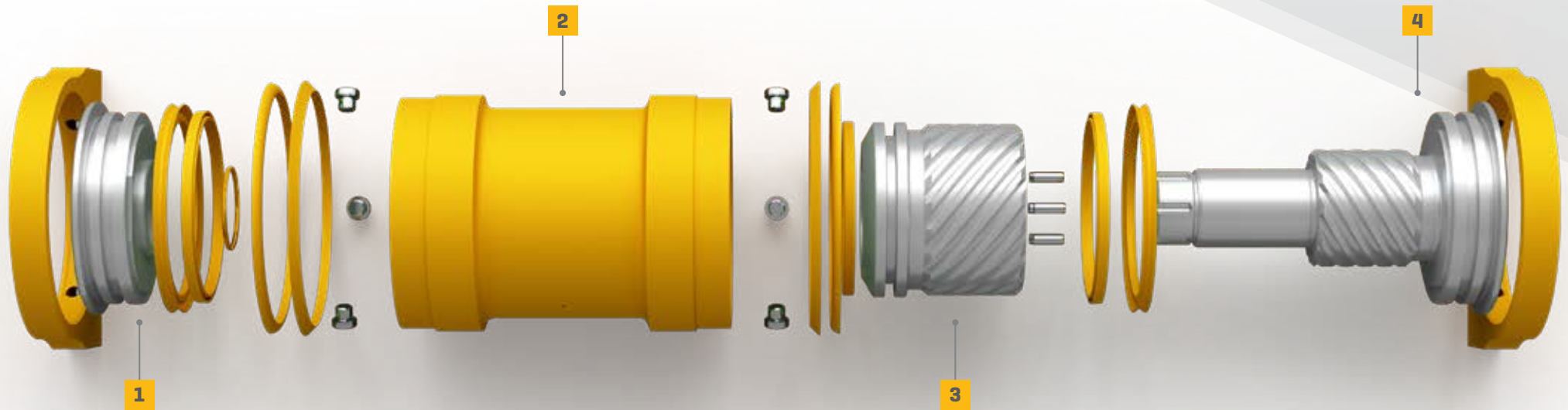

## HELICAL GEAR ACTUATOR

This actuator provides rotational torque and durability suitable for construction sites that require significant force. Unlike conventional cylinders, which may lose power depending on the angle, the tilt motor delivers consistent torque to support precise operation.

**MAINTENANCE-FREE OPERATION:** No need for relubrication and readjustment.

The advanced helical gear technology enables a tilt angle of up to 180 degrees to the left and right, surpassing the capabilities of cylinder-type tilt couplers. This design delivers maximum efficiency and versatility across a broader range of work environments.



**Made in Germany**

With over 20 years of experience and more than 50,000 in operation, you can be assured of proven performance.

# D-LOCK PROTILT™ COUPLER

## PRODUCT ADVANTAGES

### 3.5-15 TONNE EXCAVATORS

1. The screw connection is reinforced with a key.

This method has been applied for many years for rotary actuators used in mining and industry. It guarantees the highest degree of safety and stability.

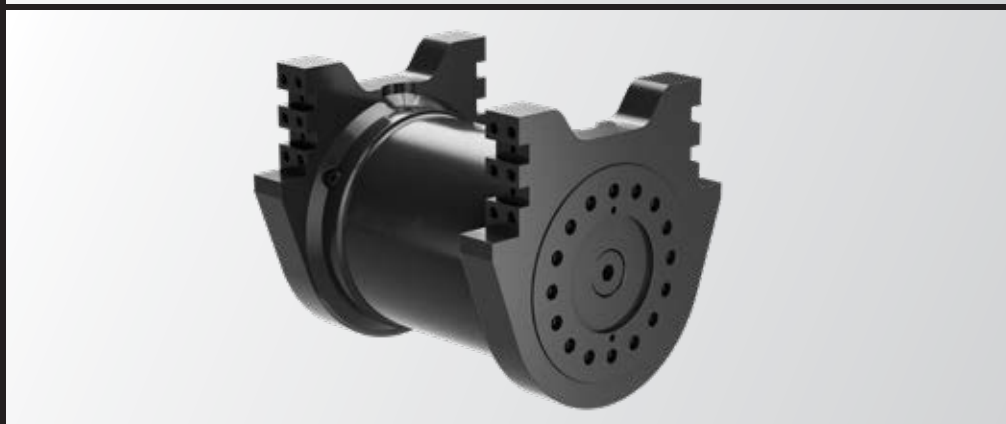

### 16-65 TONNE EXCAVATORS

1. Bolt length increased.
2. Thread engagement length increase.
3. Bolt configuration updated to allow for a more narrow coupler and increased overall strength.

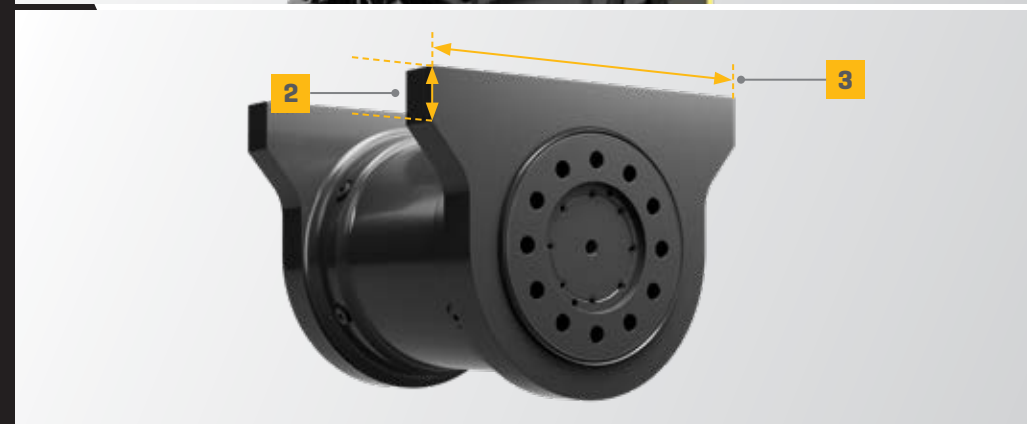
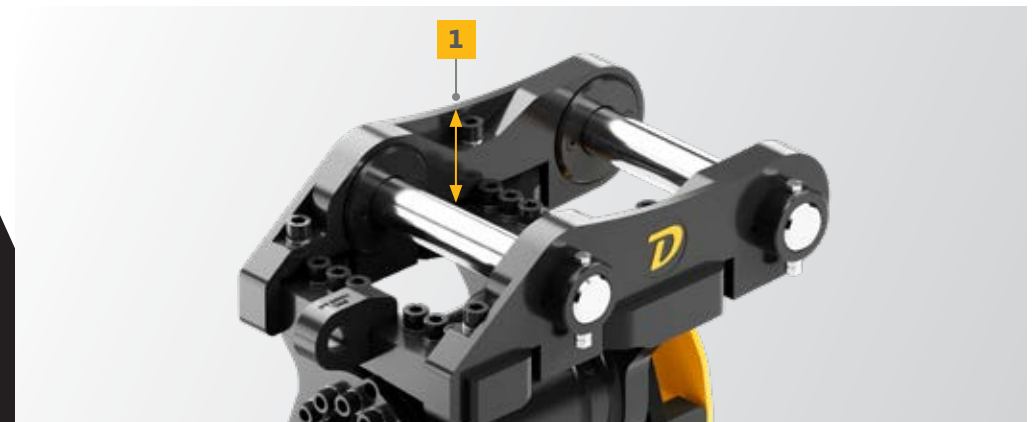



# D-LOCK PROTILT™ COUPLER

## PRODUCT ADVANTAGES

### LOW MOUNTING HEIGHT

The design features a reduced tip radius, which helps to optimise digging force by minimising losses associated with height.

The height of the coupler on its own, whilst important, has no effect until the bucket is fitted - hence, bucket selection is also an important factor.

You should always measure breakout based on the tip radius of the coupler and bucket, and not just calculate based on coupler dimensions, as the horizontal offset on coupler pins between the dipper pin and the open C can greatly affect the results.

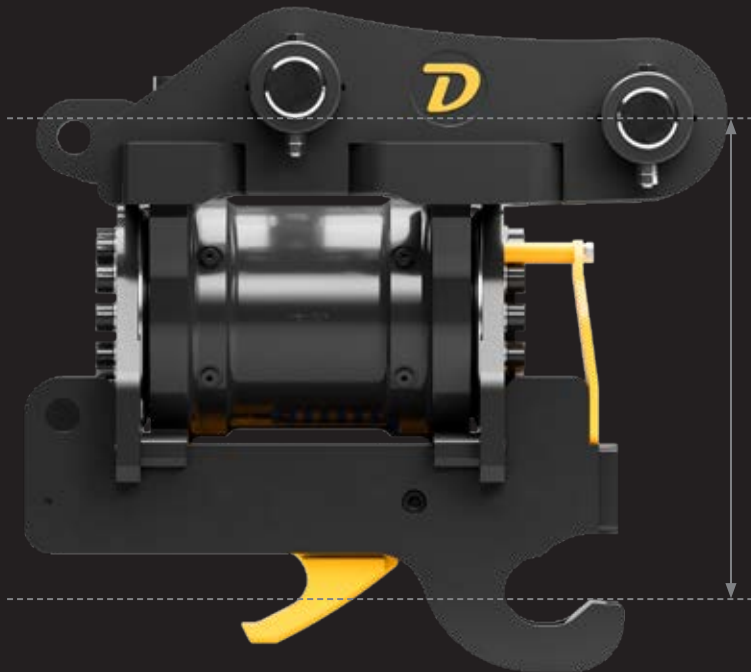

### NARROW MOUNTING WIDTH

The D-Lock Protilt™ features a narrow mounting width, engineered to facilitate excavation in standard trench sizes to any necessary depth. This design enables efficient operation within confined spaces, minimizes interference, and enhances visibility of the work area.

#### Less Material Excavation:

Narrower attachment tools can be used, considerably reducing the working width.





1.5-8 TONNE  
EXCAVATORS 180°



16-29 TONNE  
EXCAVATORS 140°  
32-65 TONNE  
EXCAVATORS 100°



14 TONNE  
EXCAVATORS 140°

# OTHER

# IMPROVEMENTS

- GPS bracket standard on all models 140 class and above
- New open C design provides increased wear limits
- The new open C design features a ramp, and locking relies on surfaces instead of edges, giving a greater wear allowance and superior locking

## DHT DESIGN FEATURES

- DHT080 and larger now all multi-pin diameter
- All models have jaw stop
- New cast jaw with nib

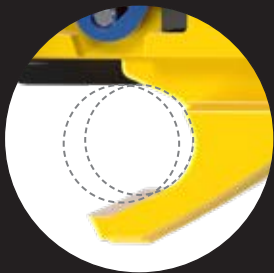

If hydraulic engagement force is lost, reaction forces will push the jaw back against spring pressure until the pin contacts the horizontal nib. At this point, the horizontal reaction force is eliminated and the pin remains locked.

During normal operation, the angled face of the jaw clamps the pin under hydraulic engagement force from the cylinder.



Lock can only move horizontally. Working forces create a vertical reaction.

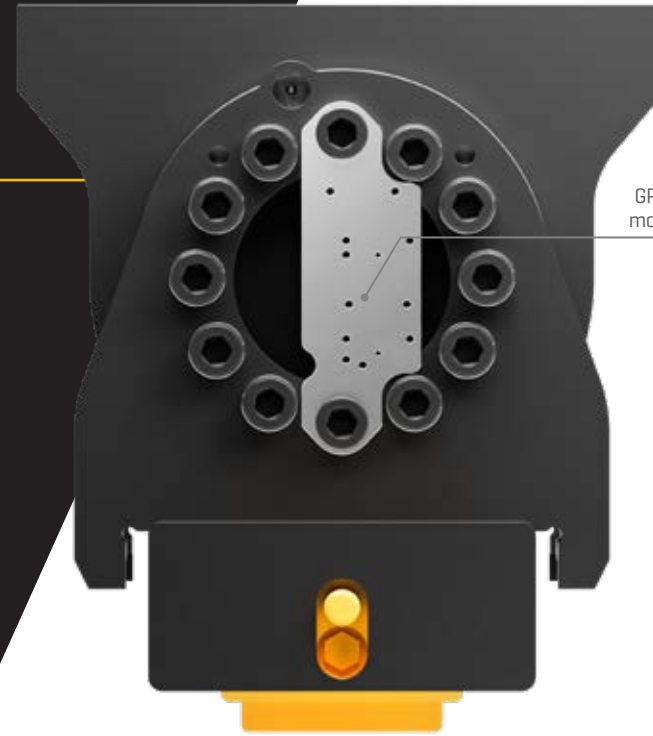

GPS bracket standard on all models 140 class and above

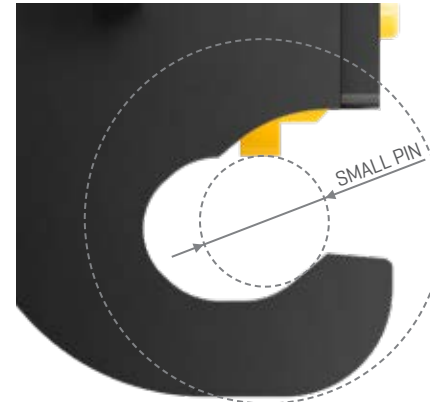

PIN LOCKED BY SURFACES, AWAY FROM WORN EDGES

## THE DIFFERENCES ARE IN THE DETAILS

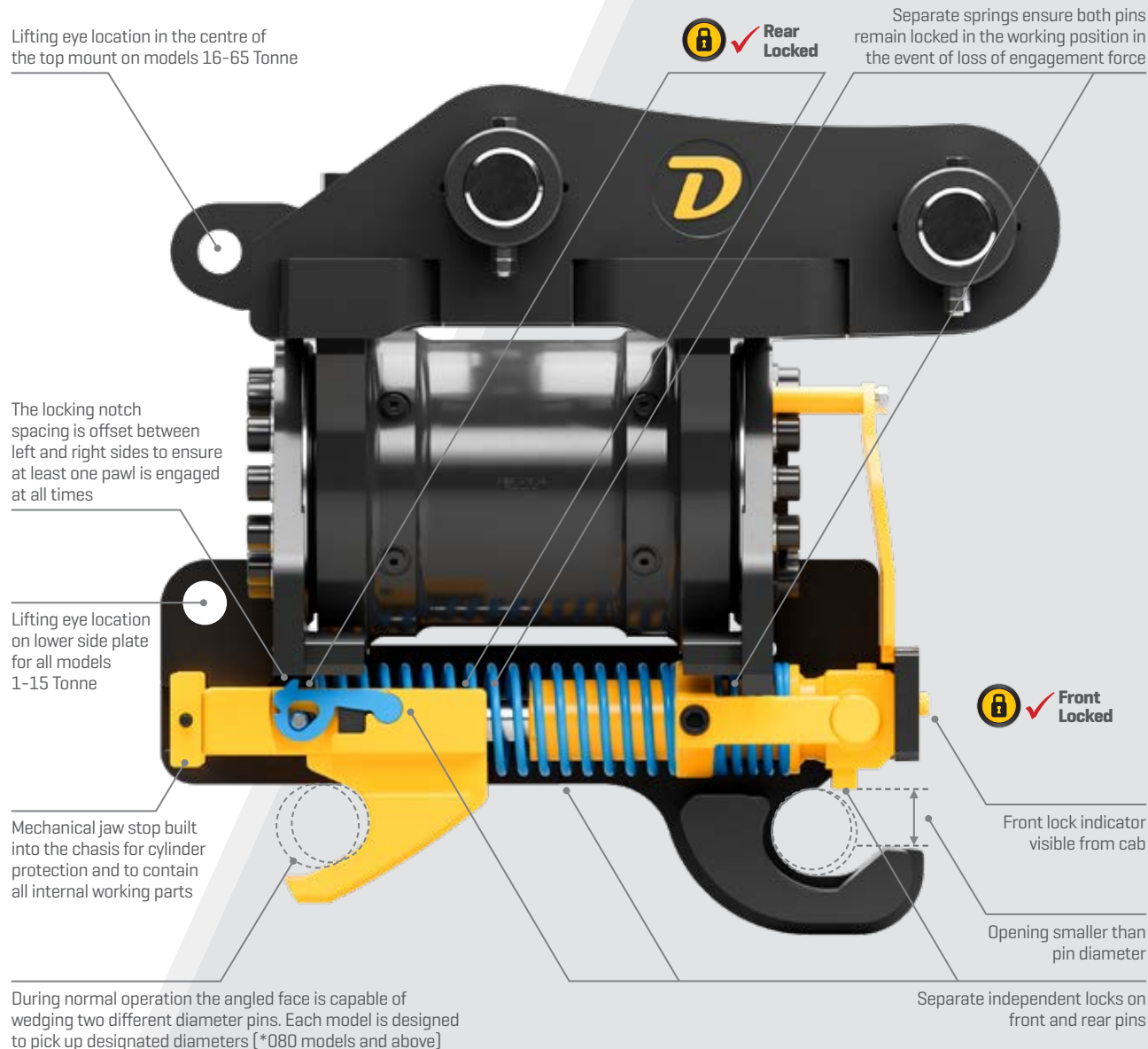

## THE DOHERTY DUAL-PIN LOCKING PLUS (DPL+) SYSTEM

- Front lock automatically engages the moment the rear jaw is activated, negating any chance of the bucket falling off if the operator misses the rear pin.
- DPL+ safety system locks both front and rear pins in the event of loss of engagement forces, and the primary jaw/lock is backed up by a 3rd independent heavy-duty compression spring.
- DPL+ safety system ensures attachments cannot swing on the front pin in the event of loss of engagement forces.
- D-Lock Coupler primary lock: The sliding jaw primary lock allows for multi-pin centres to be accepted, and is operated by a unique double-skinned, double-acting hydraulic cylinder rated for continuous use at 350 BAR and tested to 400 BAR. No pressure reducer is required.
- DPL+ locking system locks both front and rear pin independently of the primary lock.

*Compliant to Australian standard AS13031, WorkCover NSW Position paper WC01783, European EN474 standard, ISO 13031 International standard and all major contractor policies. Compact design, minimal moving parts and no complicated operating sequence to follow are just a few of the features which put the D-Lock Pratilt™ at the forefront of coupler performance worldwide.*

# D-LOCK PROTILT™ COUPLER PRODUCT RANGE



3.5-8 TONNE MODELS  
180°



16-29 TONNE MODELS  
140°



12-15 TONNE MODELS  
140°



32 - 45 TONNE MODELS  
100°



*\*Images may differ from actual product for a specific weight class.*

## HORIZONTAL BOLT (035 - 140)

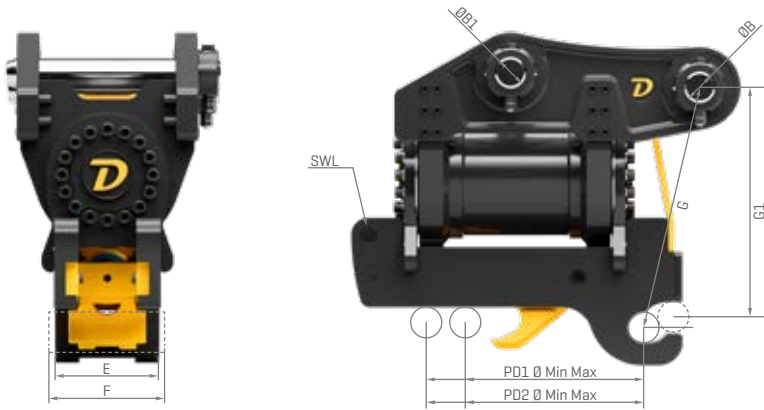

## VERTICAL BOLT (180 AND ABOVE)

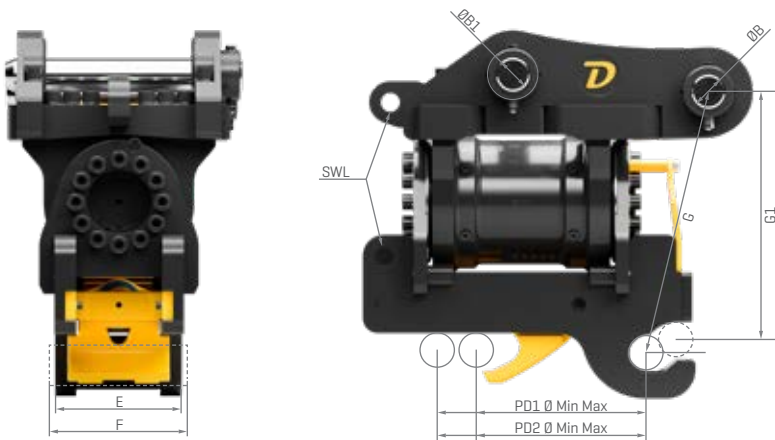

# D-LOCK PROTILT™ COUPLER UNIVERSAL MODEL - KEY DIMENSIONS

ALL DIMENSIONS ARE IN MM, ALL UNIVERSAL COUPLERS INCLUDE PINS.

Copyright Doherty Engineered Attachments Ltd, Doherty products are patent protected. All information contained herein is strictly confidential and intended for the individual or entity it is addressed/distributed to. Copies/unauthorised distribution is strictly prohibited. Doherty Engineered Attachments Ltd reserves the right to amend specifications/detail without prior notification.

Weight class	Coupler type	Version	Weight from [KG]	B-B1 - Pin Ø	E - Base width	G - Pin to pin offset	G1 - Vertical offset	SWL [KG]	Jaw**	Pin pickup dimensions	Pin pick up range [mm]
035	DHT035-200-40-158-A-120	C	98	40	120	362	352	1500	A	38/40	176-215 / 178-220
055	DHT055-234-45-190-I-144	F	145	45	144	407	397	2000	I	45	199-256
055	DHT055-245-45-190-J-144	F	145	45	144	407	397	2000	J	45	224-281
055	DHT055-285-45-190-K-144	F	145	45	144	407	397	2000	K	45	250-306
080	DHT080-293-50-218-U-164	F	232	50	164	460	451	4500	U	50/55	277-326 / 283-331
080	DHT080-312-50-238-V-164	F	232	50	164	460	451	4500	V	50/55	342-388 / 351-405
140	DHT140-390-65-295-A-217	D	380	65	217	509	497	9000	A	60/65	346-406 / 355-422
140	DHT140-405-65-295-A-217	D	380	65	217	509	497	9000	A	60/65	346-406 / 355-422
180	DHT180-432-70-332-B-279	A	564	80	279	640	629	9000	B	70/80	385-452 / 398-480
180	DHT180-463-70-301-B-279	A	564	80	279	640	629	9000	B	70/80	385-452 / 398-480
180	DHT180-435-80-3327-B-279	A	564	80	279	640	629	9000	B	70/80	385-452 / 398-480
240	DHT240-460-80-360-A-299	B	685	80	299	633	617	15000	A	80/90	430-490 / 443-520
240	DHT240-475-80-360-A-299	B	685	80	299	633	617	15000	A	80/90	430-490 / 443-520
290	DHT290-500-90-376-A-299	B	848	90	299	696	691	17000	A	80/90	430-490 / 443-520
290	DHT290-500-90-410-A-299	B	875	90	299	696	691	17000	A	80/90	430-490 / 443-520
290	DHT290-500-90-376-A-319	B	848	90	319	696	691	17000	A	80/90	430-490 / 443-520
290	DHT290-500-90-410-A-319	B	875	90	319	696	691	17000	A	80/90	430-490 / 443-520
290HD	DHT290HD-510-90-430-A-319	B	970	90	319	732	721	17000	A	80/90	430-490 / 443-520
350	DHT350-535-90-433-H-345	F	1115	90	345	728	716	23000	H	90/100	487-556 / 502-586
350	DHT350-585-100-440-H-345	F	1115	100	345	728	716	23000	H	90/100	487-556 / 502-586
350	DHT350HD	B	1590	To suit*	345	836	828	23000	H	90/100	487-556 / 502-586
350	DHT550	B	1768	To suit*	420	915	910	23000	J	100/110	547-613 / 559-641
350	DHT550	B	1768	To suit*	420	915	910	23000	K	110/120	562-623 / 574-651
350	DHT550	B	1768	To suit*	420	915	910	23000	L	100/110	616-682 / 628-710

All dimensions are in mm unless otherwise stated. All universal couplers include pins. Other models available on request. Weights are computer calculated and may vary between models. F - Width c/w clipper plates = To suit Host Machine. \*To suit = To suit Host Machine. \*\*Other jaws available on request.

# D-LOCK PROTILT™ COUPLER

## CHECK LIST/COMPLIANCE/COMPARISON

- Features Doherty D-Lock ✓
- Picks up multi-pin centres ✓
- Picks up multi-pin diameter 080 class and above ✓
- Only requires 2 hydraulic lines for the lock cylinder ✓
- Locks front pin in event rear pin is not engaged ✓
- Dual independent mechanical safety locks on both front and rear pin ✓
- Additional safety built in with heavy-duty compression spring preventing primary lock to release in the event of loss of engagement force ✓
- Prevents implement swinging on front pin in event of loss of engagement forces ✓
- No feed tube on lock cylinder from head port ✓
- Cylinder has internal safety check valve ✓
- Cylinder spike protection on 140 class and above ✓
- 350 BAR operating pressure ✓



COUPLER DECAL



DOHERTY iLINK

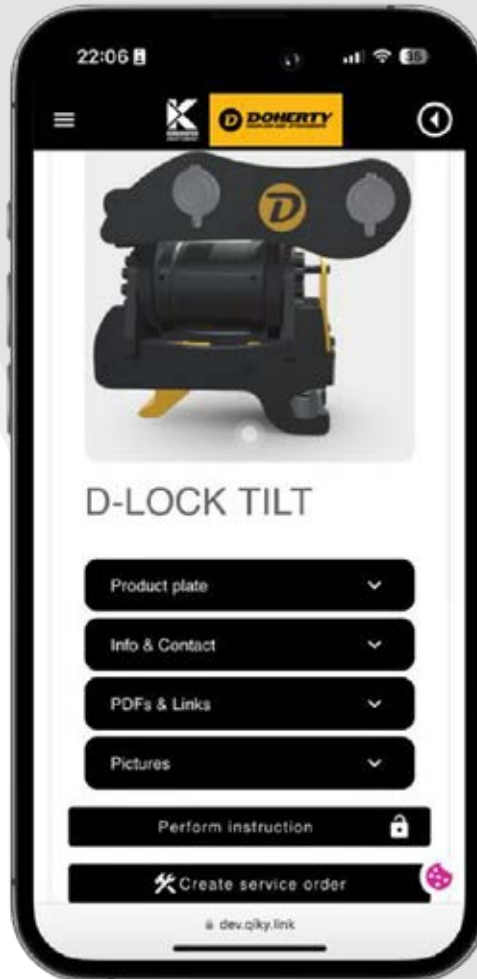

CAB DECAL



## DOHERTY iLINK

### DOHERTY QR CODE

The Doherty Smart QR code is your product ID tag digital twin. Scan the QR code, which is unique to your product serial number, to access the following:

- Parts views
- Product manual
- Service schedule
- Digital training
- Training videos
- Product registration
- Extended warranty registration
- Complete service history

The Doherty Smart QR code integrates with our After Sales software, ensuring access is at both our and your fingertips.

All Doherty attachments are fitted with a QR code and / or supplied as a decal for fitment in a safe and protected location.

The QR code is a digital twin of the ID tag and contains all the information unique to your product. Scan the code to access the serial number, parts views, product manuals, training videos, the PD sheet, and more.



# NOTES



# NOTES



WEBSITE



LINKEDIN



FACEBOOK

**Doherty Engineered Attachments Ltd**

**NZ** +64 [0]7 574 3000 | **AUS** 1800 057 021 | **E** sales@dohertydirect.net

**New Zealand** | HEAD OFFICE - Postal: PO Box 9339, Greerton, Tauranga 3142, New Zealand. Physical: 98 Paerangi Place, Tauriko, Tauranga 3110, New Zealand

**Australia** | BRISBANE - Postal: PO Box 701, Annerley, QLD 4103, Australia. Physical: 498 Progress Road, Wacol, QLD, 4076, Australia  
MELBOURNE - Factory 4, 21-22, National Drive, Hallam, VIC 3803, Australia

**WWW.DOHERTYDIRECT.NET**



**ISO 9001:2015**  
QUALITY MANAGEMENT



**ISO 14001:2015**  
ENVIRONMENTAL MANAGEMENT



**ISO 45001:2018**  
OCCUPATIONAL HEALTH & SAFETY

© Copyright Doherty Engineered Attachments Ltd, Doherty products are patent protected. All information contained herein is strictly confidential and intended for the individual or entity it is addressed/distributed to. Copies/unauthorised distribution is strictly prohibited. Doherty Engineered Attachments Ltd reserves the right to amend specifications/detail without prior notification.